



Main Features

- 8 Pole
- 250mm Cavity Size
- Double Cross Coupling
- Tunable Across Band
- Temperature Stabilization
- Output Monitor Probe

Electrical Specifications

Frequency range	470-806MHz		
ADJUSTING DATA	DVB-T/T2	ATSC 1.0/3.0	ISDB-T
Insertion Loss	$f(0) \leq 0.40\text{dB}$	$f(0) \leq 0.5\text{dB}$	$f(0) \leq 0.55\text{dB}$
	$f(0) \pm 3.8\text{MHz} \leq 1.05\text{dB}$	$f(0) \pm 2.7\text{MHz} \leq 0.7\text{dB}$	$f(0) \pm 2.79\text{MHz} \leq 1.15\text{dB}$
	$f(0) \pm 3.9\text{MHz} \leq 1.2\text{dB}$	$f(0) \pm 2.93\text{MHz} \leq 0.9\text{dB}$	
Attenuation	$f(0) \pm 4.2\text{MHz} \geq 4\text{dB}$	$f(0) \pm 3.5\text{MHz} \geq 10\text{dB}$	$f(0) \pm 3.15\text{MHz} \geq 7\text{dB}$
	$f(0) \pm 6.\text{MHz} \geq 30\text{dB}$	$f(0) \pm 6.\text{MHz} \geq 45\text{dB}$	$f(0) \pm 4.5\text{MHz} \geq 31\text{dB}$
	$f(0) \pm 12\text{MHz} \geq 51\text{dB}$	$f(0) \pm 9\text{MHz} \geq 63\text{dB}$	$f(0) \pm 9\text{MHz} \geq 61\text{dB}$
Harmonic Attenuation	$\geq 50\text{dB}$ up to 1.2GHz	$\geq 50\text{dB}$ up to 1.2GHz	$\geq 50\text{dB}$ up to 1.2GHz
Return loss / VSWR	$\leq -25\text{dB}/1.12$	$\leq -25\text{dB}/1.12$	$\leq -25\text{dB}/1.12$
Group delay variation	$< 500\text{ns}$	$< 300\text{ns}$	$< 550\text{ns}$
Temperature Stability	$< 1\text{kHz/K}$		
Max Power Output	5K W		
Impedance	50 Ω		

Environmental Specifications

Operating Temperature Range	-10°C to +55°C
Max Operating Temperature (Body)	65°C
Relative humidity	5% - 95%
Barometric pressure	55 KPa -106KPa

anywavecom.net

300 Knightsbridge Parkway | Suite 150 | Lincolnshire | IL | 60069

Phone: +1 (847) 415 2258 Fax: +1 (847) 415 2112

UHF 5kW Bandpass Filter

Product Specifications

BPF-8-U-5K-158 / 318

Part Number: 202644.01 / 202645.01



Mechanical Specifications

Connectors (Input / Output)	1 5/8" EIA	202644.01
	3 1/8" EIA	202645.01
Output Monitor Probe	N female	
Weight	47kg	
Outer Dimension (mm)	1028 * 584 * 384mm	
Mounting	Wall	
Packing	1 Piece per box	

anywavecom.net

300 Knightsbridge Parkway | Suite 150 | Lincolnshire | IL | 60069

Phone: +1 (847) 415 2258 Fax: +1 (847) 415 2112

UHF 5kW Bandpass Filter

Product Specifications

BPF-8-U-5K-158 / 318

Part Number: 202644.01 / 202645.01

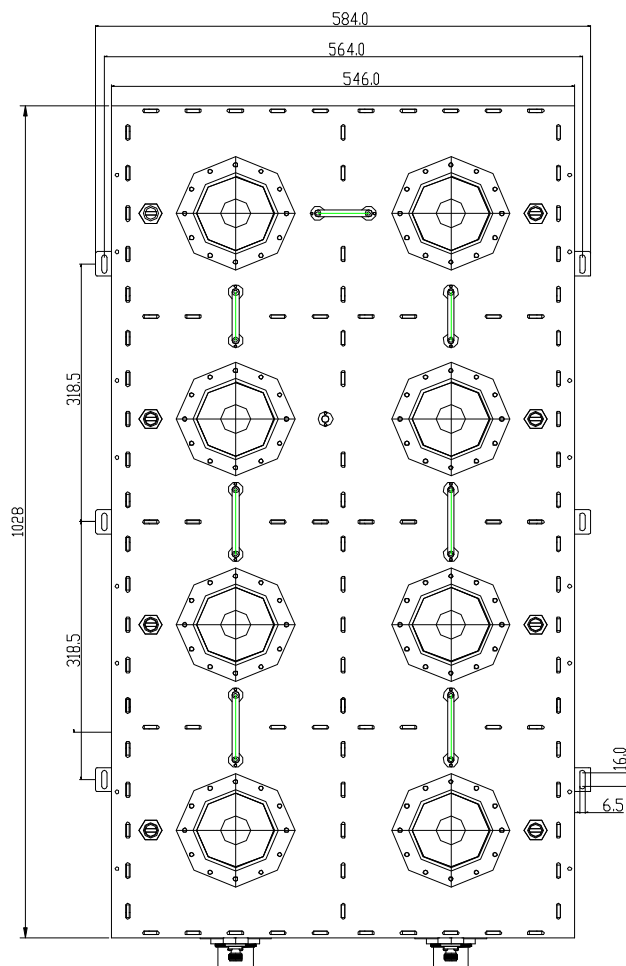
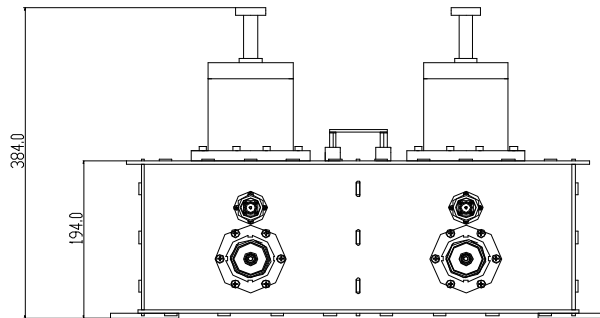

anywavecom.net

300 Knightsbridge Parkway | Suite 150 | Lincolnshire | IL | 60069

Phone: +1 (847) 415 2258 Fax: +1 (847) 415 2112