



ANYWAVE
COMMUNICATION TECHNOLOGIES



MAGMA SERIES
PRODUCT BROCHURE

HIGH POWER LIQUID COOLED SOLID STATE UHF TV TRANSMITTER

BROADBAND

**REDUNDANT
HOT
SWAPPABLE
POWER
SUPPLIES**



**25KW IN
A SINGLE
CABINET**

The Magma Series – Forging a New Path



Introduction

The Anywave **MAGMA** series of Liquid Cooled TV transmitters provides the broadcaster with the greatest power density and highest operating efficiencies in digital transmitters today. The **MAGMA** series delivers a broadband UHF solution (CH14 – CH36) with peak levels of performance and reliability. These Solid State transmitters range in output power from 5KW ATSC/OFDM to 150KW ATSC/OFDM, with up to 25KW ATSC output from a single rack. They operate across all digital TV standards including DVB-T, DVB-T2, ATSC, ATSC3.0, ISDB-T and DTMB. The **MAGMA** series incorporates the powerful correction capabilities of the Anywave digital exciter platforms.



Key Facts

- ✓ Multi-standard capability: DVB-T, DVB-T2, ATSC, ATSC3.0, ISDB-T, DTMB, NTSC, and PAL
- ✓ Implements latest state-of-the-art Asymmetrical Broadband Doherty Technology with Transmitter efficiency up to 40% (UHF)
- ✓ Modular for better reliability and ease of maintenance
- ✓ Superior Liquid Cooling system incorporates Friction Stir Welded and Graphene Enhanced Thermal Management technologies
- ✓ Optitune™ technology automatically optimizes performance and efficiency at any power level
- ✓ Redundant hot swappable Power Supply Units
- ✓ Built-in AVQ performance monitoring optional
- ✓ Remote monitoring and control via Web Browser and SNMP

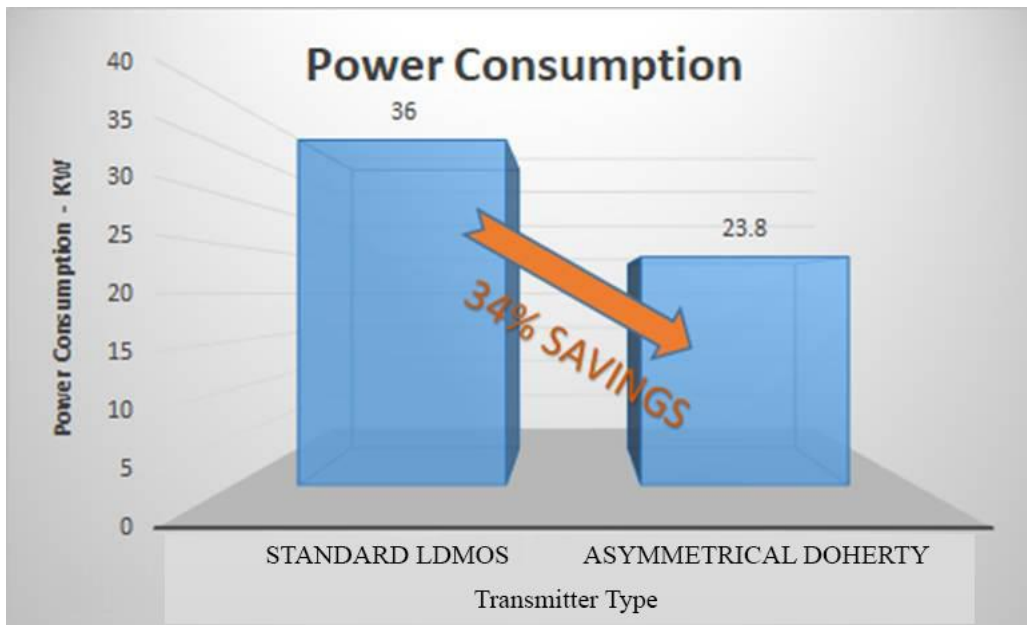

ANYWAVE

COMMUNICATION TECHNOLOGIES



General Overview

The Anywave **MAGMA** series implements the latest state of the art devices and technologies, forging a new path in high efficiency, high power, liquid cooled transmitter design. Dual front panel touchscreen monitors provide easy navigation and control as well as detailed operation and performance monitoring of the entire system. With over 450 self-monitoring sensors, the **MAGMA** preventive monitoring system side-steps problems before they occur - providing greater peace of mind.

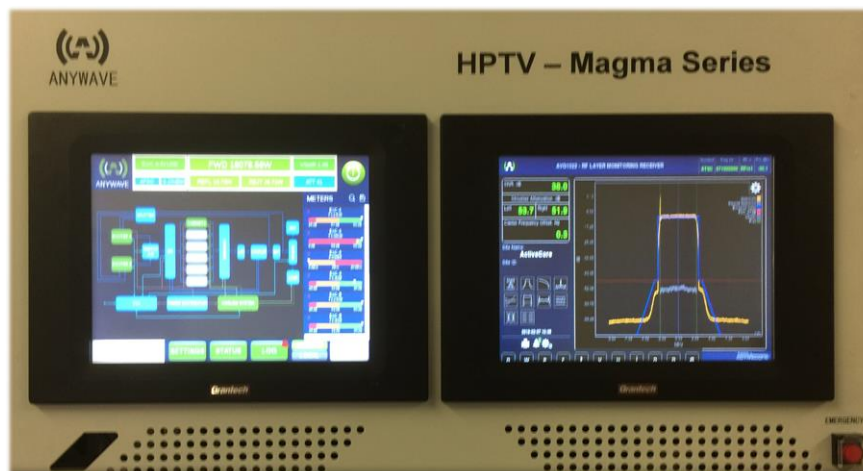

Innovative DDRF™ (Direct Digital RF) broadband automatic balancing technology achieves near perfect RF performance with shoulder levels exceeding -60 dB and out of band spurious also greater than -60 dB, all based on an ultra low noise floor.

The transmitter includes a digital ultra-wideband phase noise processing technology that automatically detects and compensates phase noise to achieve unparalleled performance.



ANYWAVE

COMMUNICATION TECHNOLOGIES



5.0 kW ATSC
5.0 kW OFDM

7.5 kW ATSC
7.5 kW OFDM

10.0 kW ATSC
10.0 kW OFDM

12.5 kW ATSC
12.5 kW OFDM



“Magma ... a hot fluid or semifluid material below or within the earth's crust from which lava and other igneous rock is formed by cooling...”

The Magma Series
- forging a new path



ANYWAVE

COMMUNICATION TECHNOLOGIES



The Anywave **MAGMA SERIES** of Liquid Cooled TV transmitters provides the broadcaster with the greatest power density and highest operating efficiencies in digital transmitters today. Up to 25kW ATSC output with unparalleled performance in a single cabinet.

15.0 kW ATSC
15.0 kW OFDM

20.0 kW ATSC
20.0 kW OFDM

25.0 kW ATSC
25.0 kW OFDM



ANYWAVE

COMMUNICATION TECHNOLOGIES



The Anywave **MAGMA SERIES** - Combine 2 to 6 cabinets to produce up to 150 kW ATSC output power.

50.0 kW ATSC
50.0 kW OFDM

150.0 kW ATSC
150.0 kW OFDM



Highest Power Density

- 16 x ultra high efficiency broadband power transistors per 3RU Amplifier delivers highest power density available today
- 10 PAs in a single rack provides 25kW liquid cooled TX with smallest footprint available today
- Combining up to 6 cabinets produces 150 kW ATSC output power



ANYWAVE

COMMUNICATION TECHNOLOGIES



Intelligent System Design

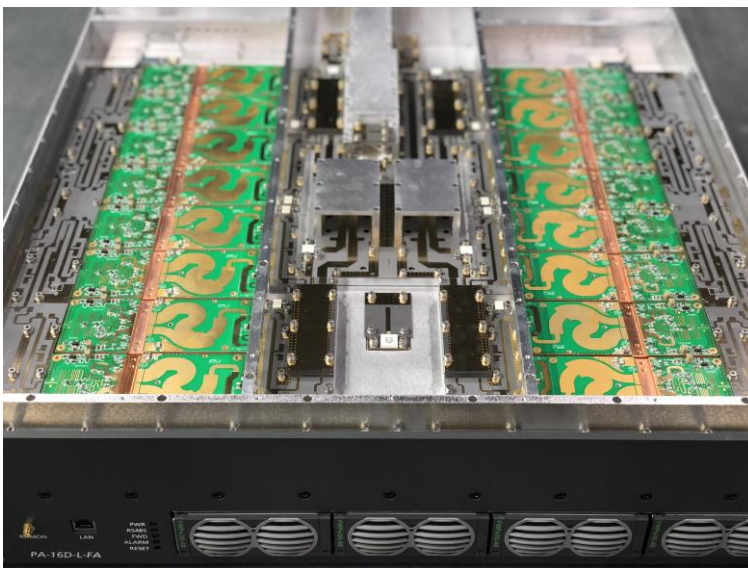
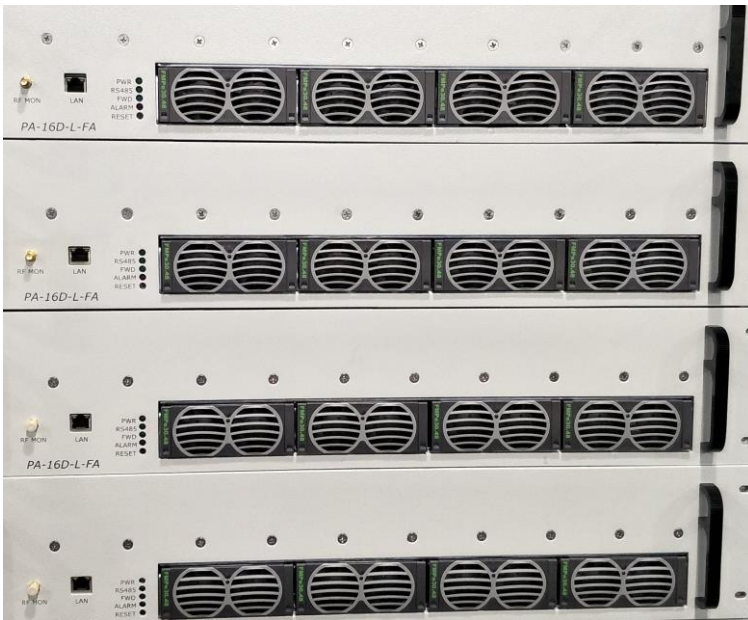

- 4 x 3000W (100% redundant) hot-swappable high-capacity power supplies per PA
- Telco grade AC/DC PSU, self current balancing with variable speed controlled fans
- Redundant & Smart Pumps, Blowers, and Fans operate at reduced optimal levels, even with a failed AC mains phase
- Over 450 self-monitoring system sensors (power levels, voltages, currents, temps, pressures, flows, equipment status, etc.)

Intelligent Self-monitoring System = Easy to operate





Friction Stir Welding and Graphene Enhanced Thermal Management Technology

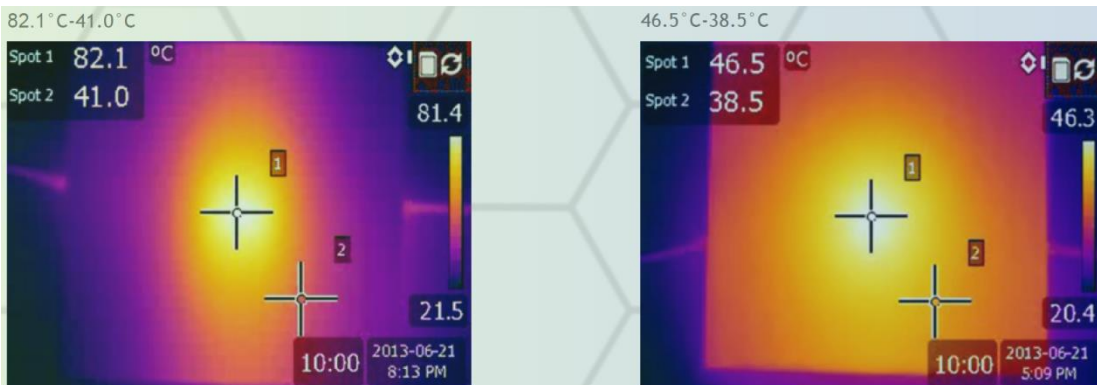

Without Graphene

With Graphene

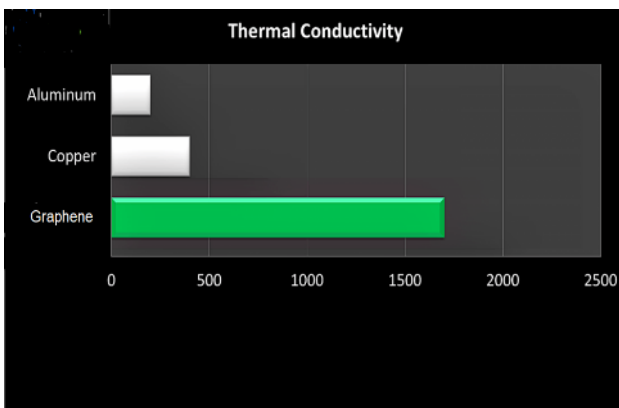

- Graphene's heat conductivity is 4 times better than copper and 8 times better than aluminum
- Friction Stir Welding provides best thermal performance - one piece, same material, lower pressure drop - long life, more reliable operation with balanced parallel cooling
- Cooler operation means better performance, higher reliability, and longer life

ANYWAVE

COMMUNICATION TECHNOLOGIES



Optitune™ Technology

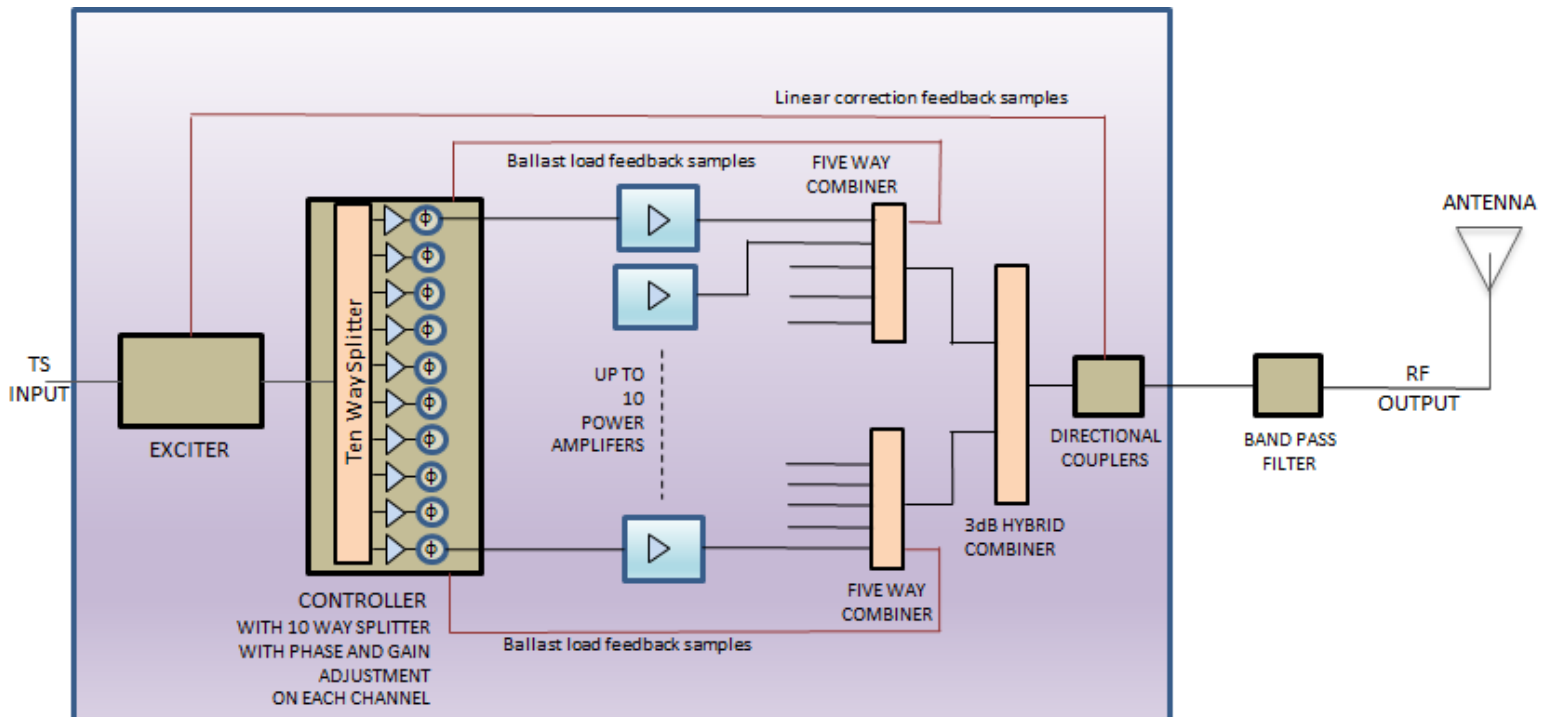

- Self-calibrating, automatic, adaptive phase and gain matching of all PA modules (up to 10 amplifier modules per cabinet, up to 6 cabinets)
- Automatically balances entire system in gain and phase within 10 minutes to achieve maximum output power (minimizes combiner losses) and optimal operating efficiency (minimizes operating costs)





AVQ Monitoring



- Real time signal quality monitoring including spectrum, shoulders, constellation diagram, eye diagram, MER, frequency response, impulse response, group delay, CCDF, etc.
- Built-in performance monitoring eliminates the need for costly test equipment
- Upgradable to ATSC3.0

ANYWAVE

COMMUNICATION TECHNOLOGIES



Exciter Specifications



Signal Inputs

- TS Inputs: 2 Transport Stream with loop out, DVB-ASI only
Connector: BNC female 75 Ω
- RF Input: Frequency: VHF or UHF
Bandwidth: 6 MHz
Connector: BNC female 50 Ω
Level: -85 dBm ~ -15 dBm
AWGN TOV: ≤ 16 dB (ATSC A/53 operation)
Equalization Range (-1 μ s ~ 0 μ s): ≤ -2 dB
Equalization Range (0 μ s ~ 17 μ s): ≤ -3 dB
Adjacent Channel Rejection ($N \pm 1$): > 30 dB

Signal Processing

- Bandwidth: 6, 7, or 8 MHz
- Supported Modes: ATSC, ATSC 3.0, DVB-T/T2, ISDB-T, DTMB
- Network Mode: MFN, SFN

RF Output

- Connector (RF Out): N-Type female 50 Ω
- Frequency: VHF/UHF in steps of 1 Hz, spectrum shifting up to ± 50 KHz
- Level: -25 dBm ~ +5 dBm in steps of 0.05 dB
- Level Stability: $< \pm 0.1$ dB
- Frequency Stability: $< 0.5 \times 10^{-7}$ (with onboard 10MHz REF), or in accordance with the Ext. GPS accuracy
- Symbol Rate: 10.762238 MHz (ATSC)
- MER: > 40 dB
- Amplitude Flatness: $< \pm 0.5$ dB
- IMD Shoulder Level (± 500 kHz): < -60 dB
- Out of Band Spurious: < -60 dB
- Pilot Amplitude Error: $< \pm 0.1$ dB (ATSC)
- Return Loss: > 15 dB
- Phase Noise (@20 kHz): < -107 dBc/Hz

Reference Clock

Internal 10MHz

- Frequency Stability: $< \pm 0.05$ ppm
- Aging: $< \pm 0.05$ ppm/year
- Output level: 0 dBm ± 3 dB

External 10MHz

- Input Level: AC coupled V (p-p) > 300 mV
- Input Connector: BNC female 50 Ω

External 1PPS

- Input Level: TTL
- Input Connector: BNC female 50 Ω

Linear and Non-linear ADPC™

- Dual Feedback Signal: BNC female 50 Ω
- Feedback level: -35 dBm ~ 0 dBm (suggested value: -15 dBm ~ -5 dBm)
- Correction is Adaptive and Automatic: No additional instruments or manual operations needed
- Continuous measurement and display of SNR and IMD
- Correction of amplitude, phase and group delay
- Up to 10 dB of MER improvement
- Up to 15 dB of shoulder improvement
- In-band flatness: $< \pm 0.5$ dB

Other

- Power Supply: 88 ~ 264 VAC, 50/60Hz
- Operating Temperature: 0° C ~ 50° C (+32°F~+122°F)
- Operating Humidity: $\leq 95\%$
- Size: 1 RU, 19" Wide
- Weight: 15 LBS



ANYWAVE

COMMUNICATION TECHNOLOGIES

Cooling System



- Cooling system implements 100% redundant, most efficient pumps on the market with all stainless steel pipes
- 100% redundant heat exchanger blowers with individual temp and speed control
- Automatically analyzes system parameters, finds optimum settings and continuously adjusts operation to changes in demand – optimized performance with minimum energy consumption
- Cooling system can be integrated into the same rack for single transmitter with up to five PAs



ANYWAVE

COMMUNICATION TECHNOLOGIES



Power Requirements / Dimensions

HPTV Series - UHF ⁽¹⁾							
Standard	All ⁽²⁾						
	2	3	4	5	6	8	10
Number of Amplifiers / rack	2	3	4	5	6	8	10
Output Power (RMS) ATSC	5,000	7,500	10,000	12,500	15,000	20,000	25,000
Output Power (RMS) COFDM	5,000	7,500	10,000	12,500	15,000	20,000	25,000
Output Power (Peak) Analog	11,500	17,250	20,000	N/A	32,000	N/A	N/A
Output Connector	3-1/8"				4-1/16"		
Height (inches / mm)	77.2 / 1960						
Width (inches / mm)	30 / 760						
Depth (inches / mm)	47.3 / 1200						
AC Input Voltage	208 VAC, three phase						
AC Input Frequency	50 / 60 Hz						
Consumption - ATSC 1.0 - KW	13.4	20.0	26.7	33.4	40.0	53.4	65.8
Current Rating Per ϕ - ATSC 1.0 - A	37.2	55.6	74.1	92.6	111.2	148.2	182.8
Consumption - OFDM - KW	13.4	20.0	26.7	33.4	40.0	53.4	65.8
Current Rating Per ϕ - OFDM - A	37.2	55.6	74.1	92.6	111.2	148.2	182.8
Consumption - Analog (Peak) - KW	21.4	32.0	37.1	N/A	59.4	N/A	N/A
Current rating per ϕ - Analog - A	59.5	88.9	103.1	N/A	165.1	N/A	N/A

(1) Power measured before Band Pass Filter

(2) Standards include ATSC, ATSC 3.0, DVB-T, DVB-T2, ISDB-T, CMMB, DTMB, NTSC, PAL

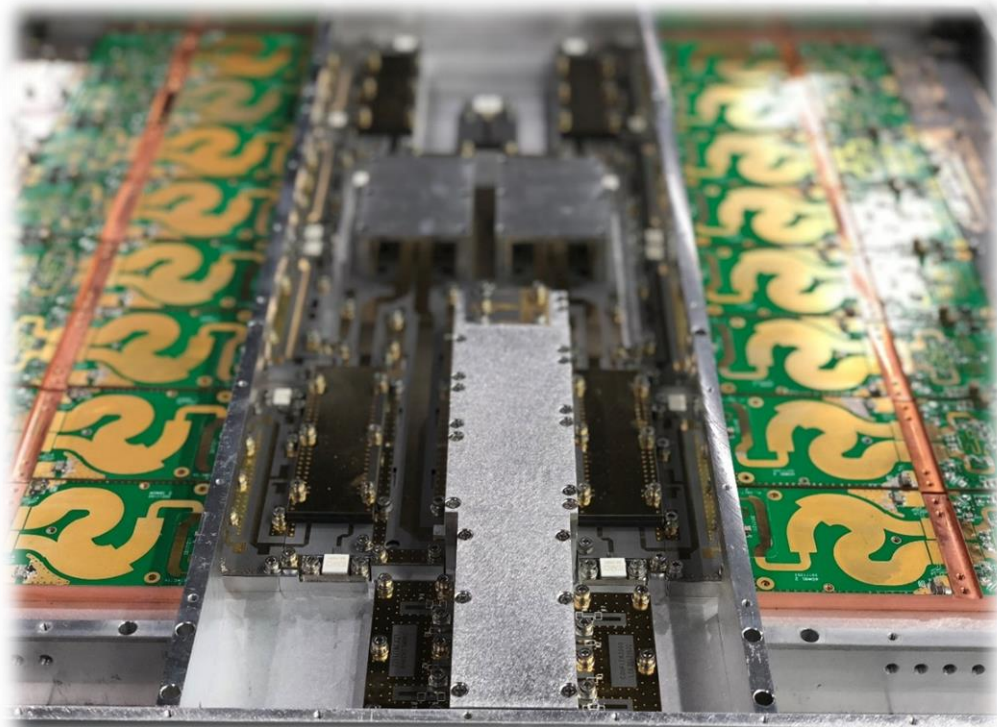



General Specifications

Specifications

Digital TV

Standards		DVB-T, DVB-T2, ATSC, ATSC3.0, ISDB-T, DTMB
Channel bandwidth	DVB-T	6/7/8 MHz
	DVB-T2	1.7/5/6/7/8 MHz
	ATSC	6 MHz
	ISDB-T	6/8 MHz
	DTMB	8 MHz
Inputs	DVB-T, DVB-T2, DTMB	2 × ASI (HP/LP), 75 Ω BNC, 2 × RJ-45
	ATSC	2 × SMPTE310M or 2 × ASI, 75 Ω BNC, 2 × RJ-45
	ISDB-T	2 × BTS, 75 Ω BNC, 2 × RJ-45
		2 x ETI, BNC 75 Ω/high impedance, 2 x RJ-45

General data

Frequency range	UHF	470 MHz to 700 MHz
Supply voltage		208 V; 3-phase, 4 wire (L1,L2,L3,GND)
Max. installation altitude	> 2000m on request	2000 m above sea level
Operating temperature range		+1 °C to +45 °C
Relative humidity (max.)		95 %, non-condensing
Synchronization - ref frequency		10 MHz, 0.3 V to 5 V (V_{pp}) or TTL, BNC
Reference pulse		1 Hz, TTL, BNC

Operation

Display unit with touchscreen and LEDs	Local operation and display
Ethernet interface, RJ-45	Local, remote, standard web browser
	Network management interface via SNMP
Parallel remote interface	Floating contacts for messages and commands

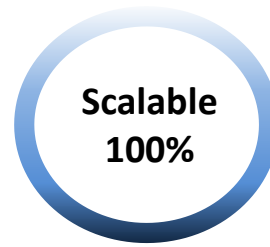

www.anywavecom.net



Anywave Communication Technologies

Email: sales_us@anywavecom.com

Phone: +1 (847) 415 2258

Fax: +1 (847) 415 2112

Address: 100 N Fairway Drive, Suite 128
Vernon Hills, IL 60061

Website: www.anywavecom.net

