



ANYWAVE



GRANITE SERIES
PRODUCT BROCHURE

MEDIUM POWER AIR COOLED SOLID STATE UHF TV TRANSMITTER

BROADBAND

**REDUNDANT
POWER
SUPPLIES**



AIR COOLED

**12.8KW IN
A SINGLE
CABINET**

The Granite Series – Like a rock



Introduction

The Anywave **GRANITE** series of Air Cooled UHF TV transmitters provides the broadcaster with the latest state-of-the-art digital transmitter design. The **GRANITE** series delivers the highest levels of performance and reliability without costing you extra. The power capability of these forced air cooled Solid State (50V LDMOS technology) transmitters range from (all before filter) 1.6kW ATSC (1.1kW OFDM) to 12.8kW ATSC (8.8kW OFDM). They operate across all worldwide digital TV standards including DVB-T, DVB-T2, ATSC, ATSC3.0, ISDB-T and DTMB. The **GRANITE** series incorporates the powerful correction capabilities of the Anywave digital exciter platforms. In addition, the products offer many unique features not available anywhere else in the industry.



Key Facts

- ✓ Multi-standard capability: DVB-T, DVB-T2, ATSC, ATSC3.0, ISDB-T and DTMB
- ✓ Broadband – same amplifier with no retuning across US TV band 14-36
- ✓ Transmitter efficiency up to 40%
- ✓ Implements latest state-of-the-art Asymmetrical Broadband Doherty Technology
- ✓ 8 x ultra high efficiency broadband transistors provide power densities of 1.6kW (ATSC 1.0) per amplifier
- ✓ Modular for better reliability and ease of maintenance
- ✓ Optitune™ technology automatically optimizes performance and efficiency at any power level^[3]
- ✓ Redundant hot swappable Power Supply Units
- ✓ Simple and Efficient Front-to-Back Air Cooling with fan speed control
- ✓ LCD Touch Screen Control System
- ✓ Remote monitoring and control via Web Browser and SNMP

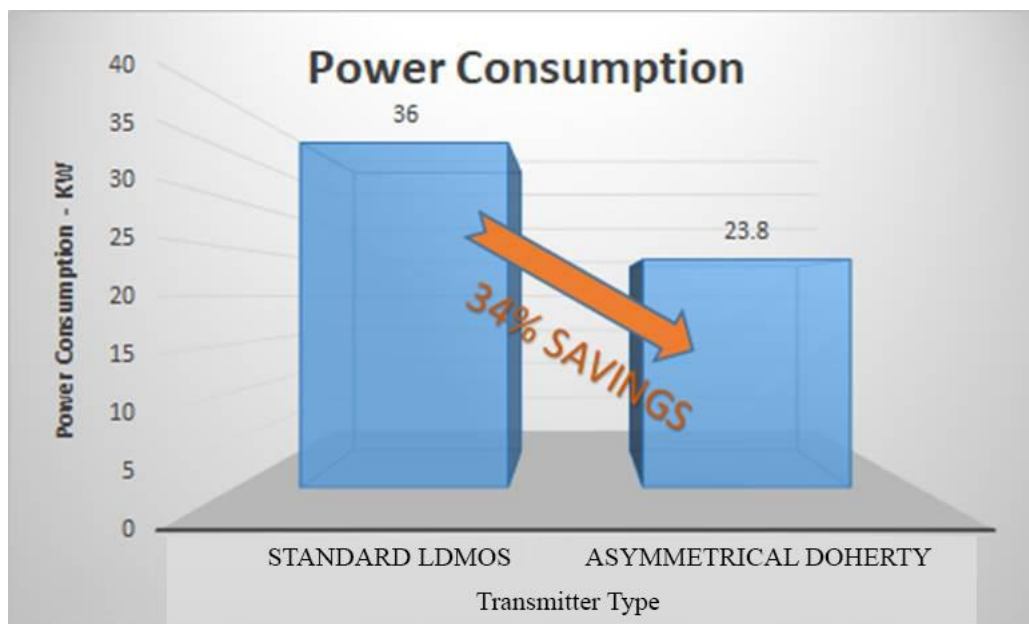

ANYWAVE



General Overview

The MHPTV transmitter is easily configured to operate as a standard transmitter or as an RF translator. Innovative DDRF™ (Direct Digital RF) broadband automatic balancing technology achieves near perfect RF performance with shoulder levels exceeding -60 dB and out of band spurious also greater than -60 dB, all based on an ultra low noise floor.

Independent feedback for adaptive linear and non-linear optimization function maximizes emission signal quality after the transmitter band-pass filter (BPF). The system level AGC (Automatic Gain Control) function includes both RF and DC AGC feedback obtaining a stable output power and performance.

The transmitter includes a digital ultra-wideband phase noise processing technology that automatically detects and compensates phase noise to achieve unparalleled performance.

The front panel of the transmitter includes a user friendly graphical display for control and status monitoring including a real time measurement and display of the shoulder levels and SNR of the transmitted signal. This control interface provides a quick guide to the operation of the entire transmitter including a real-time temperature display, an over temperature alarm, and the individual voltage and current readings of all the amplifier transistors.



ANYWAVE



1,600W ATSC
1,100W OFDM

3,200W ATSC
2,200W OFDM



The **Granite Series**
– Like a rock



4,800W ATSC
3,300W OFDM

6,400W ATSC
4,400W OFDM

8,000W ATSC
5,500W OFDM

Granite is a coarse-grained, quartz and feldspar-bearing igneous rock that is made up entirely of crystals. It forms from the slow crystallization of Magma* below the Earth's surface.

**The Granite Series,
- built to last.**

* Magma is Anywave's series of liquid cooled transmitters



ANYWAVE



The **Granite Series** has the highest power density for any high power air cooled transmitter today. Up to 12.8 KW ATSC output with unparalleled performance in a single cabinet, provides a true alternative to a liquid cooled system.

9,600W ATSC

6,600W OFDM

12,800W ATSC

8,800W OFDM



The **Granite Series**
– Like a rock



ANYWAVE



Transmitter Block Diagram

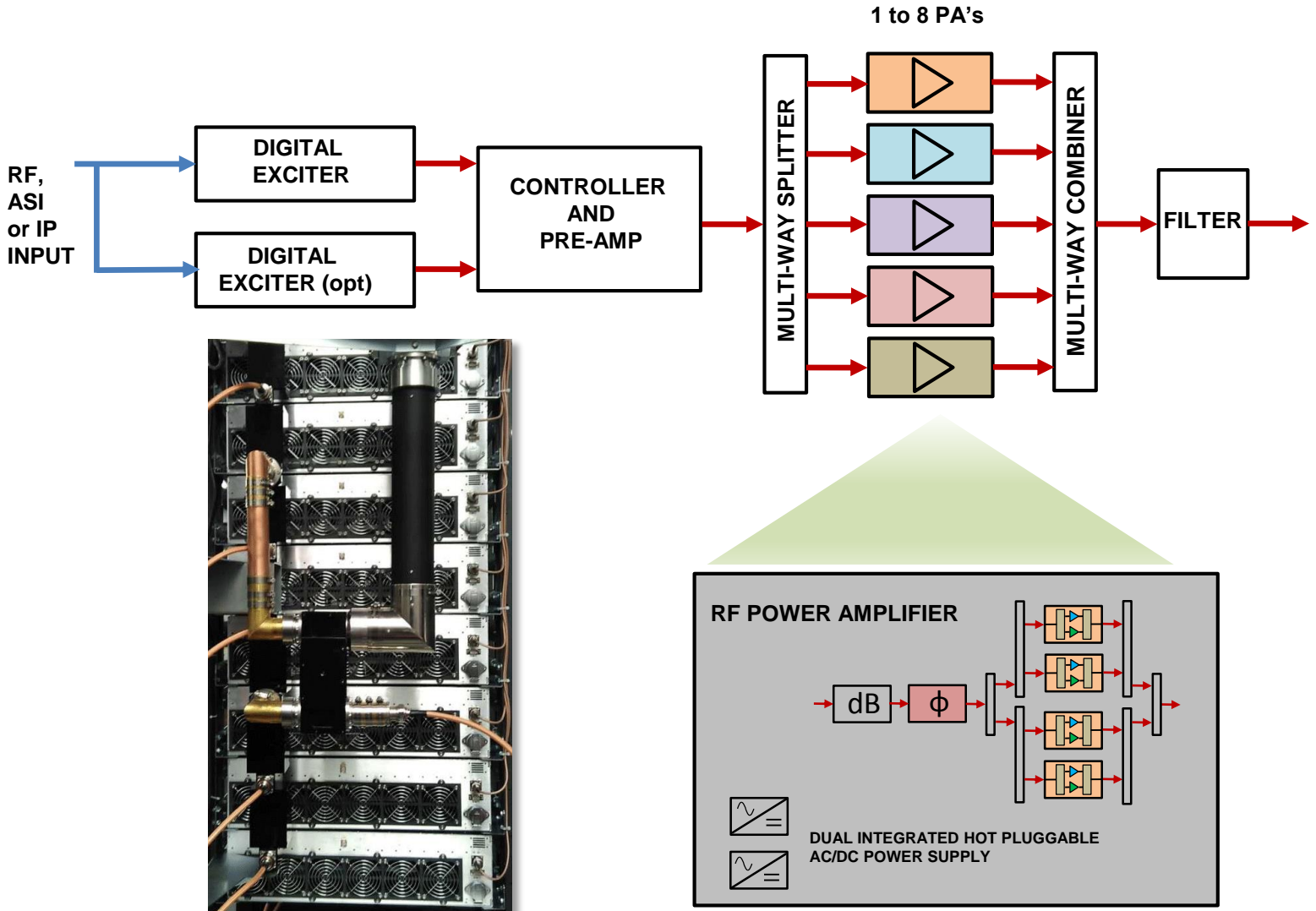

Highest Power Density

- 8 x ultra high efficiency broadband transistors per PA delivers highest power density available today
- 8 PAs in a single rack provides 12.8 kW air cooled TX with smallest footprint available today



ANYWAVE

Superior PA Design



- Dual hot-swappable, easily replaceable high-capacity power supplies



- Individual variable speed control for each fan to user configurable target temperature

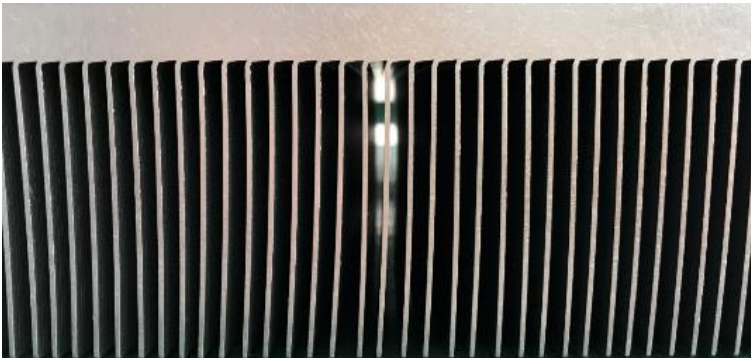

- Oversized single-piece heat-sink provides even heat distribution and enhanced heat transfer

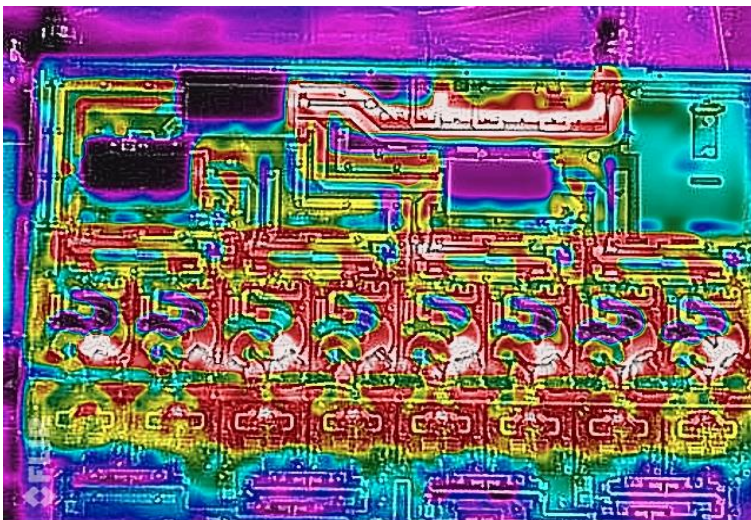

- Eliminates critical hot-spots...designed to last

**Less wasted heat
equals lower
operating costs**



ANYWAVE



Optitune™ Technology

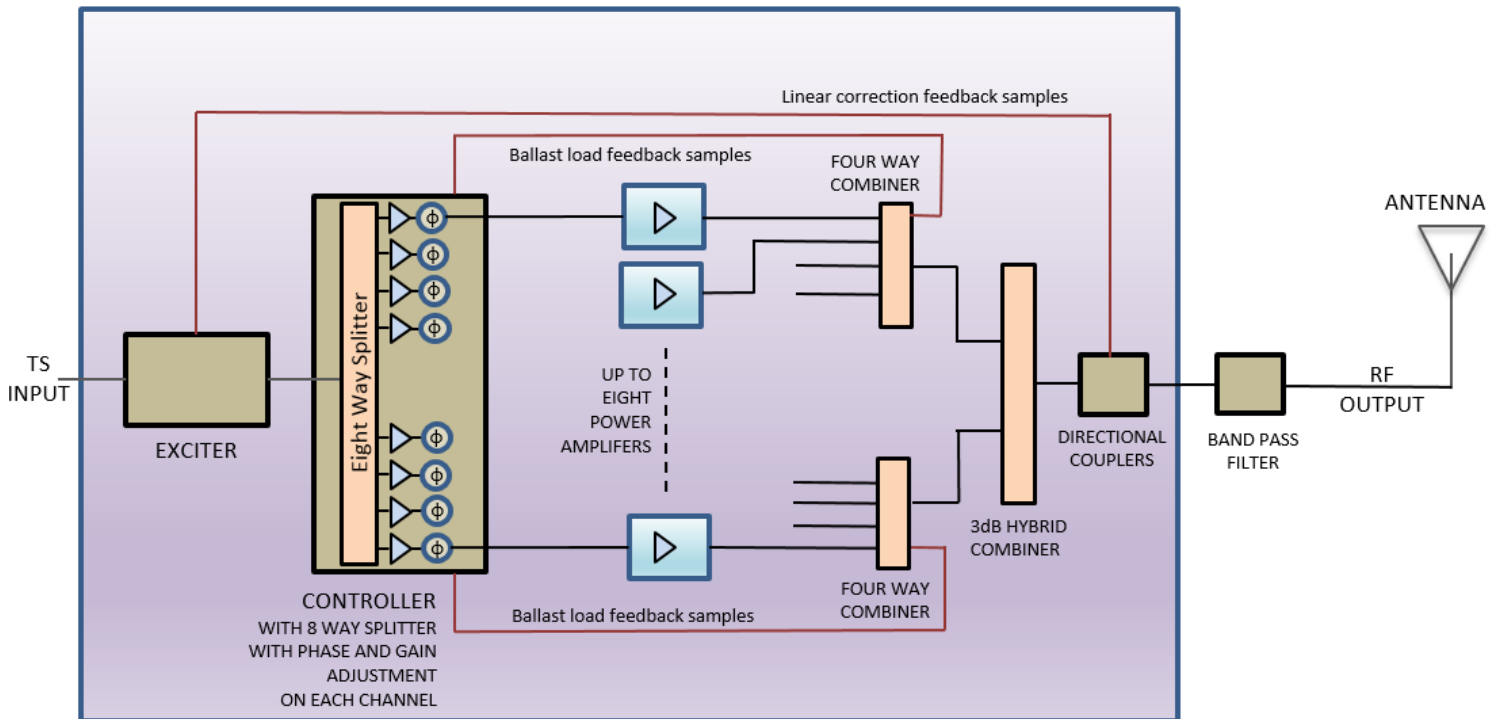

- Self-calibrating, automatic, adaptive phase and gain matching of all PA modules (up to 8 amplifier modules per rack)
- Automatically balances entire system in gain and phase within 10 minutes to achieve maximum output power (minimizes combiner losses) and optimal operating efficiency (minimizes operating costs)



ANYWAVE



AVQ Monitoring

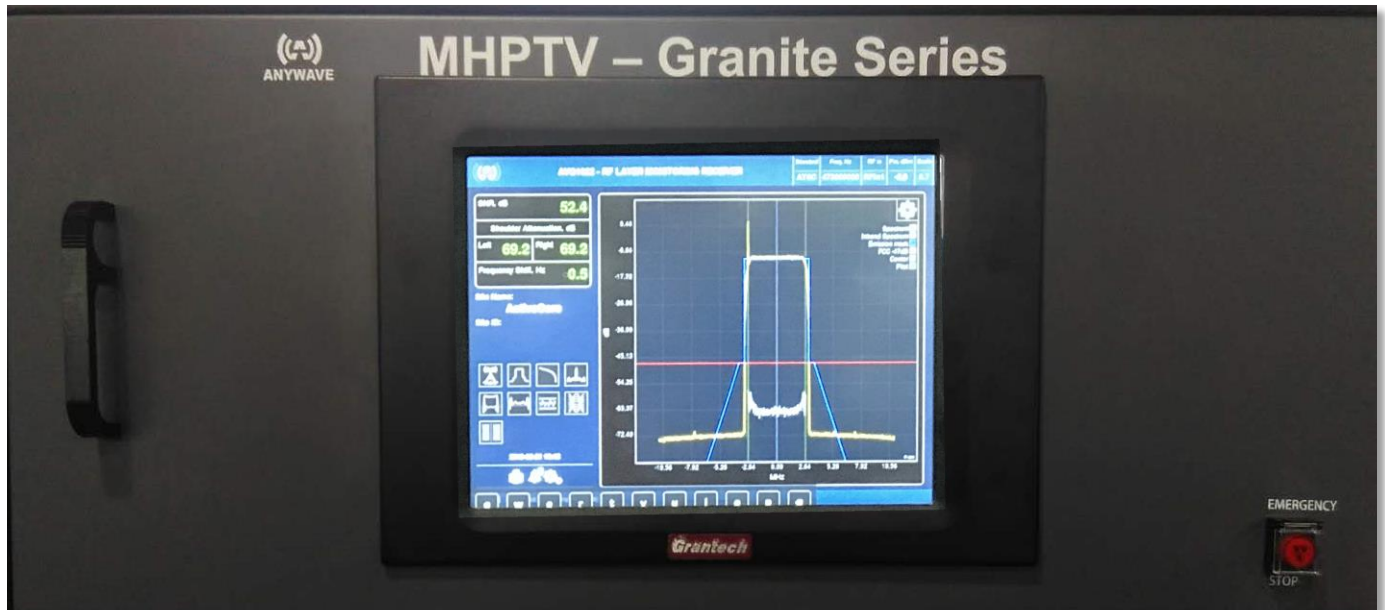

- Real time signal quality monitoring including spectrum, shoulders, constellation diagram, eye diagram, MER, frequency response, impulse response, group delay, CCDF, etc.
- Built-in performance monitoring eliminates the need for costly test equipment
- Upgradable to ATSC3.0

ANYWAVE



Easy installation and service

Installing or replacing a liquid cooled television transmitter often requires substantial construction work and expertise. In most cases it is necessary to install pipe work, flow meters, gate valves, heat exchangers, pumps, tanks, additional electrical conduit and electrical breakers. In comparison, the installation of an air cooled transmitter is far simpler. Once the RF system and electrical connections are in place, the air cooled system is typically ready to operate in a matter of hours rather than weeks. The initial cost of equipment and installation of a liquid cooled transmitter is higher than that of an air cooled system; in most situations 30% more.

Although liquid cooling has a marginally lower operating cost, the amount of time to pay-back the initial investment difference in most cases could be as much as 12 years. An Air cooled transmitter also has lower spares, replacement and maintenance costs. The new **Granite Series** air cooled transmitter from **Anywave** makes it possible to maintain with lesser qualified staff, achieve space savings and most importantly - significantly reduce initial capital expenses.

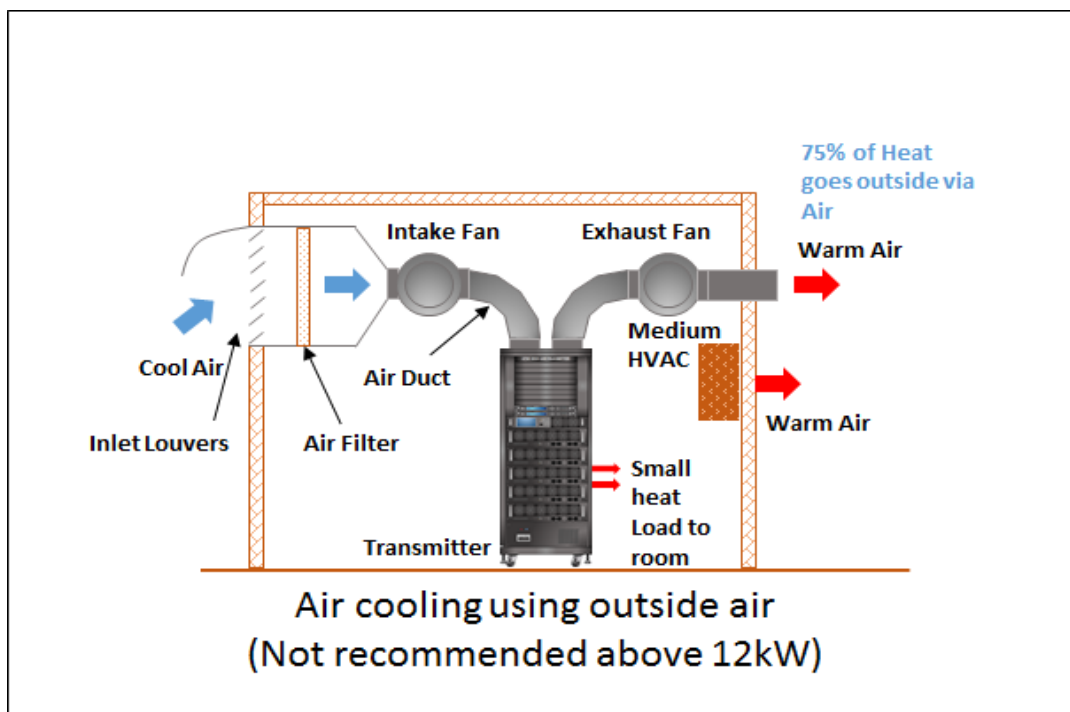

ANYWAVE



Power Requirements / Dimensions

MHPTV Series - UHF							
Number of Amplifiers	1	2	3	4	5	6	8
Output Power (RMS) ATSC [1]	1600	3200	4800	6400	8000	9600	12800
Output Power (RMS) OFDM [1]	1100	2200	3300	4400	5500	6600	8800
Output Connector	1-5/8"			1-5/8" or 3-1/8"		3-1/8"	
Height (inches/mm)	53.5/1358		70.6/1794			81.2/2063	
Width (inches/mm)	28.5/725						
Depth (inches/mm)	33.5/850			43.5/1100			
Weight(LBS/Kg)	400/182	520/236	700/318	810/367	920/418	1060/480	1280/580
AC input frequency	50/60 Hz						
AC input voltage	240 VAC Single ϕ or 208 VAC Three ϕ						
Consumption - ATSC 1.0 kW	4	8	12	16	20	24	32
Current rating per ϕ - ATSC 1.0 [2]	16.7/11.1	33.3/22.3	50/33.4	44.5	55.6	66.7	88.9
Consumption - OFDM - kW	2.75	5.5	8.25	11	13.75	16.5	22
Current rating per ϕ - OFDM [2]	11.5/7.6	22.9/15.3	34.4/22.9	30.6	38.2	45.8	61.2

[1] Power measured before band pass filter

[2] 1,2,3 PA - Current rating is for 240 VAC Single ϕ /208 VAC Three ϕ ; 4,5,6,8 PA - Current rating is for 208 VAC Three ϕ

[3] Optitune - standard on 4 amplifier versions and higher

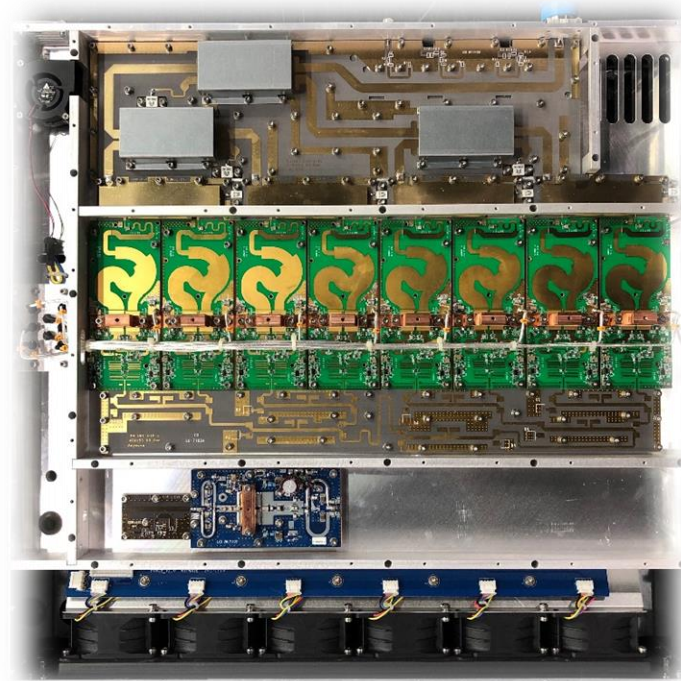

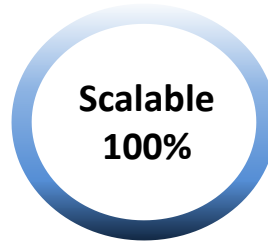

Anywave Broadcast Inc

Email: sales@anywaveus.com

Phone: +1 (847) 415 2258

Fax: +1 (847) 415 2112

Address: 100 N Fairway Drive, Suite 130
Vernon Hills, IL 60061

Website: www.anywavecom.net

